

PAPER SIZE	DRAWING NUMBER	
B SIZE	GD-J206Z	
REV	REVISION DATE	ECO
A	06-11-19	D9557

**MATERIAL:**  
 THREAD: NYLON ALLOY  
 ALL OTHER: STEEL, COATED PER TABLE BELOW.

**NOTES:**  
 1. ALL DIMENSIONS ARE REFERENCE AND IN INCHES EXCEPT AS NOTED.  
 2. MANUFACTURER'S IDENTIFICATION MARK AND YEAR OF MANUFACTURE.  
 3. CATALOG AND PART NUMBERS WITH "T" SUFFIX TO BE THERMAL DIFFUSION GALVANIZED PER ASTM A-1059.

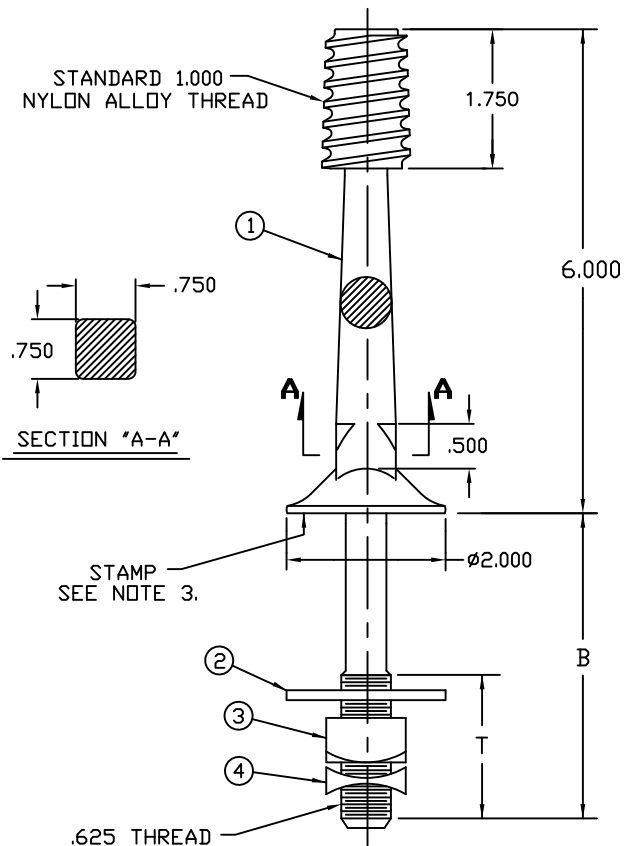

CATALOG NO.	B	T	COATING
J206Z	5.750	3.000	HDG ASTM 153
J206ZT	5.750	3.000	TDG ASTM 1059

ITEM	QTY	DESCRIPTION
1	1	STEEL PIN BODY
2	1	2.000 X 2.000 X .125 SQUARE WASHER
3	1	.625 SQUARE NUT
4	1	.625 SQ M-F LOCKNUT

TOLERANCES UNLESS SPECIFIED
INCH
0.XX
0.XXX
ANGLE



**MACLEAN  
 POWER  
 SYSTEMS**  
 11411 ADDISON STREET  
 FRANKLIN PARK, IL 60131

DRAWN BY	ENGINEER	CHECKER	CATALOG #	SCALE	DESIGN DATE
MTT	RPM	MTT	SEE TABLE	NTS	12-15-92
DRAWING TITLE / DESCRIPTION					DRAWING NUMBER
PIN X ARM W/NA THD					GD-J206Z

This drawing contains confidential information that is the property of MacLean Power, L.L.C. ("MacLean"). Use of MacLean's confidential information without MacLean's express written consent is strictly prohibited and may expose you to legal liability. If you believe that you received this material in error, please destroy it or return it to "MacLean Power, L.L.C., 11411 Addison, Franklin Park, Illinois 60131, USA."